

Rubbish Chutes Operating & Assembly Instructions

1. Purpose of Equipment

Rubbish Chute systems are intended for the guidance of falling material within the specifications of the equipment as described below. Rubbish Chute systems are **not** intended for the guidance of humans or animals, **or the movement of hazardous or toxic materials**. Rubbish Chutes are intended for vertical use.

2. Safety

2.1 Warnings

- Read and understand these instructions first before setting up or operating this equipment
- Keep these instructions accessible near the Rubbish Chutes.
- Before beginning work, one should become familiar with the working environment.
- No changes, additions or modifications may be made to the Rubbish Chutes or associated equipment.
- Do not modify, remove, bypass or override the safety devices.
- Do not use this Rubbish Chute system if there is any damage or unusual performance. Isolate the Rubbish Chute system as described in Chapter 7.1 Emergency Shutdown.
- Rubbish Chutes **must** be secured to a structure capable of withstanding the forces described in Chapter 3
- Do not operate the Rubbish Chute system if there is a risk of people being endangered by the load or the effects of using the Rubbish Chute system. Have the area around the bottom of the Rubbish Chute system barricaded off and post warning notices.
- Observe National Plant Regulations and Occupational Health and Safety Regulations.

2.2 Hazard Assessment

Please note that this checklist is indicative only. Users must perform their own Risk Assessment subject to the intended siting and use of the equipment.

Hazard	Risk	Control
Crushing or striking by the Rubbish Chutes collapsing during USE	Moderate	<ul style="list-style-type: none"> • Have the area around the bottom of the Rubbish Chute system barricaded to prevent personnel from standing near the Rubbish Chute system. • Do not place articles larger than the internal diameter of the Rubbish Chutes, or blockage and overloading may occur. • Do not use the Rubbish Chute system if blocked. • Do not use the Rubbish Chute system if overloading has occurred. • Do not allow the Rubbish Chute system to be used when maintaining the system or changing waste bins. • Ensure Rubbish Chutes are not attached to the waste bin when the bin is being moved. • Exercise care if the Rubbish Chutes are pulled out more than 2.4m from the vertical axis or the top Chute may be dislodged from its mounts. • Do not remove any weights from a counterweighted frame assembly.
Crushing by the Rubbish Chutes collapsing during ASSEMBLY	Moderate	<ul style="list-style-type: none"> • Barricade off a workspace during assembly and ensure the Rubbish Chute system is raised using safe work practices. • Ensure attachment/securing structure is of adequate strength • For counterweighted frames, do not attach Rubbish Chutes until all counterweights are installed. • Ensure that the Rubbish Chutes are correctly attached. • Assemble as per instructions and good rigging practices.
Striking or crushing by materials falling from the Rubbish Chute system.	Low	<ul style="list-style-type: none"> • Load material at the designated loading points only • Place barricading around the designated loading points to prevent spillage. • Do not use a damaged Rubbish Chute system.
Falling from height when erecting or using the Rubbish Chutes	Low	<ul style="list-style-type: none"> • Barricade area at height to prevent falls. • Use height safety equipment.
Poisoning, asbestosis,	Low	<ul style="list-style-type: none"> • Do not install or remove a Rubbish Chute system if there is a risk that it

exposure to toxic / hazardous chemicals		<p>will be used or has been used to move hazardous or toxic materials;</p> <ul style="list-style-type: none"> • Decontamination by an approved person must be made before removal; • Inform your supervisor if adjoining structures or work areas are contaminated by toxic or hazardous materials before starting work.
---	--	--

2.3 Certification

Certification to operate this equipment is not required. The person with control or management of the workplace must ensure that:

- The Operator is at least 18 years old.
- The Operator is competent to operate the equipment.

2.4 Incident Notification

- The employer, as defined by the Regulations referred to below, who has management or control of the workplace must be aware that they may have an obligation to notify WorkCover of any incidents involving this equipment. Refer to the Occupational Health and Safety Act and the Occupational Health & Safety (Incident Notification) Regulation(s) applicable to your State;
- If hazardous or toxic materials have been moved with this equipment, the Hirer has a duty of care to inform Australian Scaffolds prior to the removal or return of the equipment.

2.5 Inspections

Inspections as detailed in Chapter 6: Maintenance should be performed before Installation or Use of this equipment.

3. Specifications

3.1 Masses

- Rubbish Chute sections: 13kg
- Load Hooper sections: 9kg
- * Centre Bracket : 14kg
- * Parapet Brackets: 12kg each

3.2 Support Loading Forces

- Diverting the bottom of the Rubbish Chute system leads to an increase in the loading on the supports and increases the risk of system blockage.
- The maximum diversion of the Rubbish Chute system should never exceed 2.4m in radius from the vertical axis of the Rubbish Chute system.
- All anchorages must be capable of supporting 2.5kN
- Rubbish Chute systems must be supported at the top and at intervals not exceeding 20m to a maximum Rubbish Chute system length of 40m.

3.3 Structure Loading Chart

System length	Force "F" with vertical system	Force "F" with system deflected to 2.4m
10m	144kg	512kg
20m	288kg	623kg
30m	432kg	734kg
40m	576kg	845kg

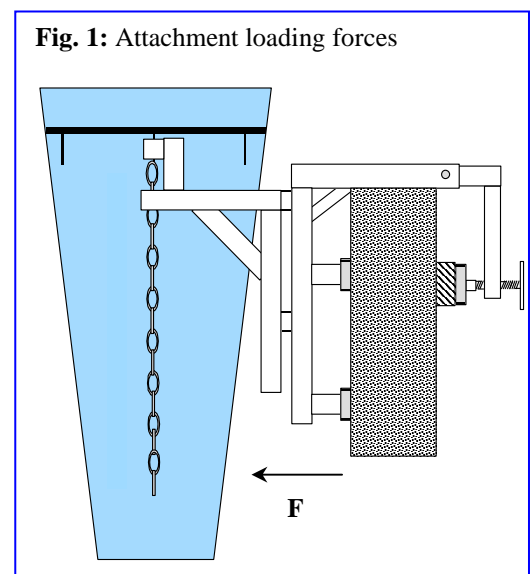

4. Description

4.1 General

Fig. 2: Rubbish Chute Components

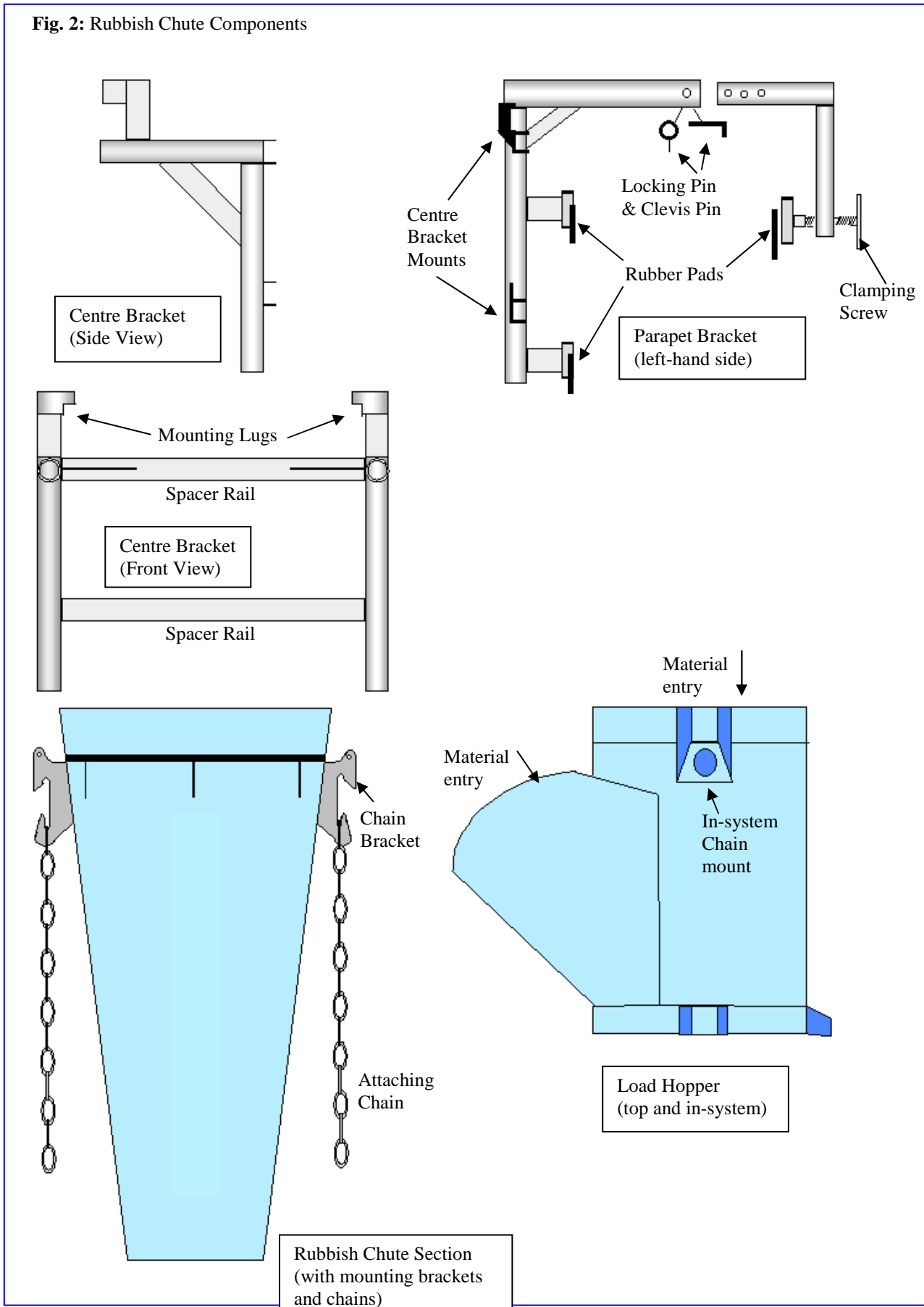

5. Operation

5.1 Pre-Operation

- Read the Warning notices in Chapter 2 and implement a Risk Assessment before starting work
- Check the condition of the equipment as described in Chapter 6.1
- Do not work beneath the Rubbish Chute system.
- Ensure a waste bin or other collection method is in place at the bottom of the Rubbish Chute system.
- Ensure the bottom of the Rubbish Chute system is barricaded to prevent personnel from entering the area while the system is in use.
- Always wear protective clothing.

5.2 Prohibitions

- Do not allow people or animals to enter the Rubbish Chute system;
- Do not use a Rubbish Chute system for movement of toxic or hazardous materials;
- Do not exceed the specifications in Chapter 3;
- Do not operate in wind speeds of more than 70km/hr;
- Do not operate if the Rubbish Chute system or any of its components are damaged;
- Do not operate if required Inspections have not been performed;
- Do not place material longer than a Rubbish Chute section or blockages may occur.

5.3 Using the Rubbish Chute system

Refer to Figure 2 in Chapter 4.2:

- Check that all material to go into the Rubbish Chute system is smaller than the inside diameter and no longer than that of a Rubbish Chute section. Break-up the material if required.
- At the top level, load material into the system by placing material into the side or the top of the Hopper.
- On multi-level Rubbish Chute systems, load material into the system through the Hopper side entry.
- Allow the material to fall down the inside of the system into the catchment area.

6. Operator Maintenance

6.1 Daily

Before the start of Installation or each work period, the person operating the Rubbish chute System should:

- Ensure the work area is clean and well arranged
- Check the security of the Rubbish Chute system and its attachments including Attaching Chains and Chain Brackets.
- Check the condition of the Rubbish Chutes and ensure damage that may cause collapse of the system, or damage that may compromise safety, has not occurred. Some wear of the last Rubbish Chute section at the catchment area is acceptable.
- Check the catchment area is not full and that further Rubbish Chute system use will not cause injury to personnel or damage to property.
- Ensure barricading and signage at the catchment area is present and legible.

6.2 Changing a waste bin or clearing the catchment area.

- Prevent use of the Rubbish Chute system by placing barriers in front of the Load Hoppers and erecting a sign stating "DO NOT USE – BIN CHANGE" at each Hopper.
- Release any ties from the Rubbish Chute system to the waste bin or over the catchment area and move the end of the Rubbish Chute system away from the immediate work area. Take care not to deflect the system too far or the top Rubbish Chute may be dislodged from its attachment, leading to a collapse.
- Change the bin or clear the catchment point.
- Retie the system to the waste bin or over the catchment area.
- Check that the top Rubbish Chute is still lodged in the attachment.
- Remove signs and barriers from the Hoppers

7. Shut-down Procedure

7.1 Emergency Shut-down

- Prevent use of the Rubbish Chute system by placing barriers in front of each Load Hopper.
- Erect a sign stating "DO NOT USE – RUBBISH CHUTES UNDER REPAIR" at each Load Hopper.
- Inform management or management's agent of the problem.

8. Installation

8.1 Transport

- Rubbish Chute sections may be stacked one inside another, allowing 16 to a pallet.
- Secure Rubbish Chutes on the pallet to prevent toppling

8.2 Installing the Window or Parapet Clamp

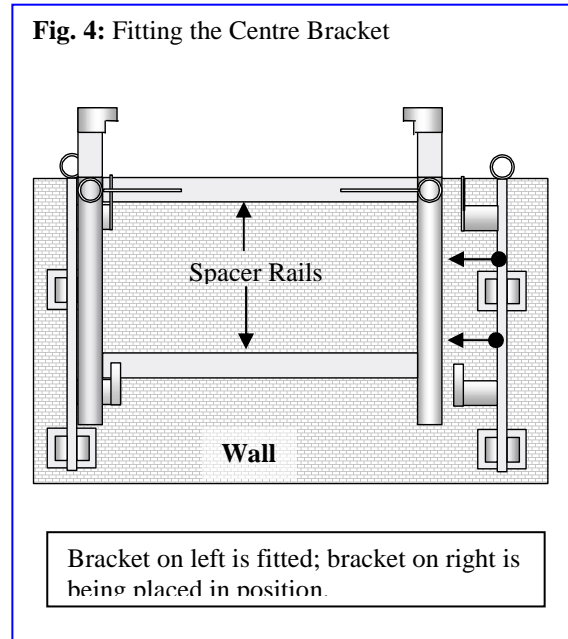
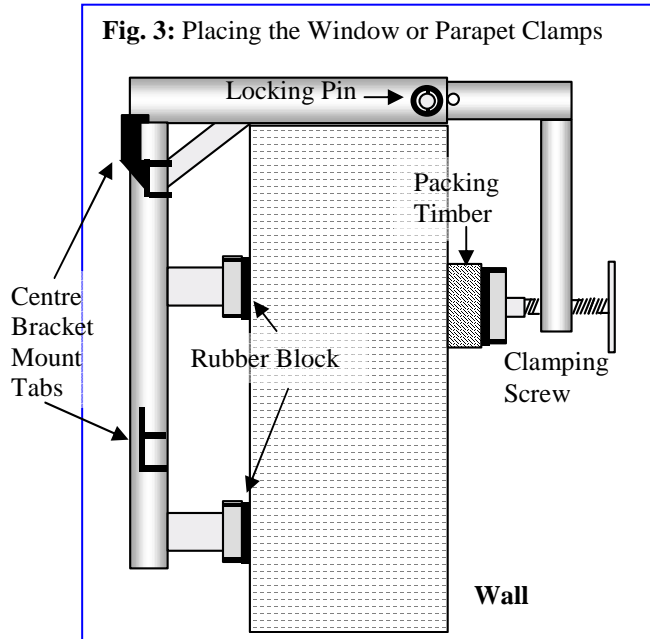

Refer to Fig. 3 and Fig. 4, above

- **MAXIMUM OF 20 CHUTES CAN BE INSTALLED FROM A PARAPET CLAMP.**
- Have the wall checked, to ensure that it is at least double brick thickness, is structurally sound and is capable of withstanding 2.5kN as an outward force.
- Select a suitable piece of hardwood timber to spread the load on the inside of the wall. The timber must be long enough to span the Centre Bracket and Clamps.
- Take the right-hand side clamp assembly. Standing at the single pad end, this bracket will have the Centre Bracket mount tabs on the left-hand side (illustrated).
- Open the Clamping Screw as far as it will go.
- Pin the two halves of the bracket together with the Locking Pin at approximately the thickness of the wall and the Packing Timber. Fit the locking Clevis Pin.
- Place the Clamp over the wall, fit the Packing Timber and tighten the Clamping Screw until just tight.
- Fit the Centre Bracket to the Clamp by placing the top and bottom Spacer Rails over the corresponding Mount Tabs.
- Place the left-hand side Clamp assembly over the wall; fit to the Centre Bracket and tighten.

8.3 Installing on scaffold

Refer to Fig. 5

- **MAXIMUM OF 40 CHUTES CAN BE INSTALLED FROM A SCAFFOLD BRKT.**
- Have the mounting scaffold checked to ensure that it is capable of withstanding 2.5kN force.
- Check that the scaffold is anchored to a structure above and below the attachment point.
- Check the scaffold is anchored at each staging within 4 metres of the attachment point.
- Fit two horizontal braces as shown
- Attach the Centre Bracket in four places with scaffold clips as shown.
- Brace the scaffold with two diagonal braces as shown.

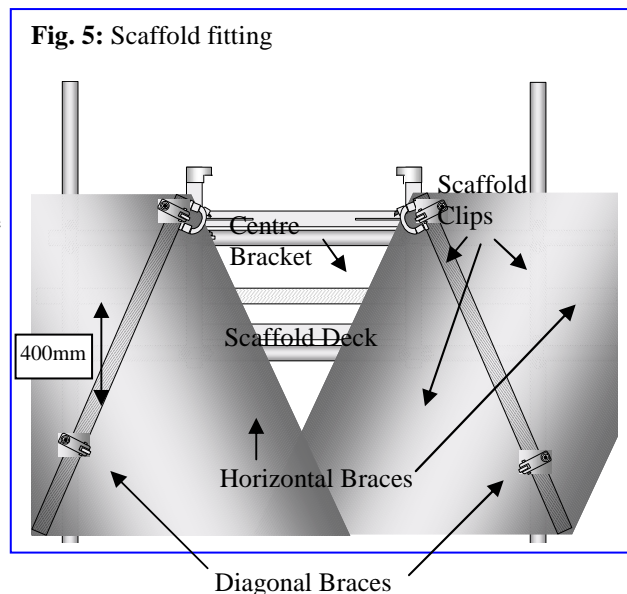

8.4 Installing a counter-weighted frame (MAXIMUM OF 40 CHUTES CAN BE USED)

Refer to Fig. 6 **Note:** Ensure that the support structure can take the mass of the counterweight frame, counterweights, rubbish chutes and any extra loads on the structure caused by blocked chutes (at least 1000kg)

Fig. 6 Counterweighted frame mount

Step 1 – place the support members (2)

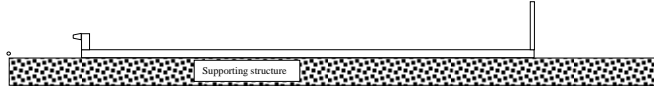

Step 2 – assemble the guard rail

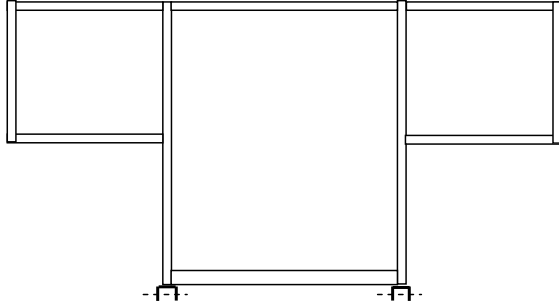

Step 3 – secure the guard rail to the support members

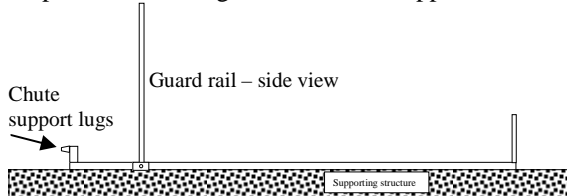

Step 4 – slide support assembly into position

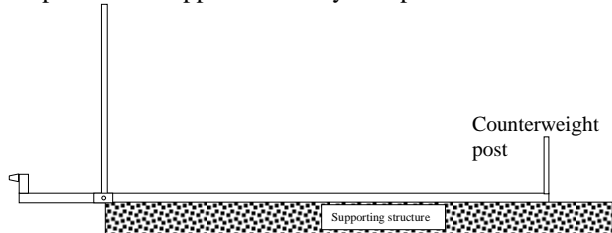

Step 5 – mount counterweights

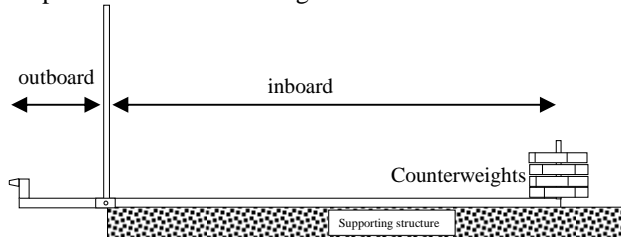

Step 6 – mount rubbish chute sections

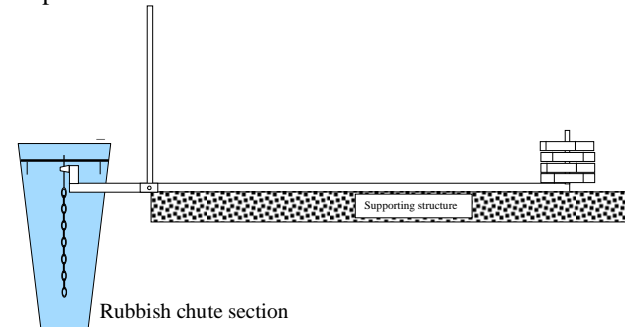

1. Lay a left-hand & a right-hand support member on the floor of the support structure away from the edge so that the risk of a fall is removed.
2. Unfold the guard rail assembly.
3. Fix to the support members at the holes provided using 2 off M12 x 100mm bolts, washers and nuts or with pins and retainers as provided.
4. Slide the support assembly into position so that the guard rail is at the edge. The table in step 5 only applies at this position (when the correct amount of support member is protruding from the edge).
5. Fit the correct number of counterweights onto the counterweight posts. Put half the total number of counterweights on each post.
The formula for calculating the number of counterweights according to the number of rubbish chute sections and hoppers is:

$$\text{Counterweights (in kg)} = \frac{\text{Chute mass} \times \text{Outboard} \times \text{SF}}{\text{Inboard}}$$

where

Chute section mass = 13kg each

Chute hoppers = 9kg each

Outboard = projection (0.50m)

Inboard = length on structure (2.3m)

SF = safety factor (6 for counterweights*)

Counterweights = 18kg

Example:

10 chute sections

1 load hopper

therefore chute mass = $10 \times 13 + 9\text{kg} = 139\text{kg}$

counterweights = $\frac{139\text{kg} \times 0.5 \times 6}{2.3}$

(kg)

= 90.65kg

= 5 counterweights

(use 6: 3 on each post)

Qty of chutes with one load hopper	Qty of counterweights
5	6
10	10
15	14
20	20

Note: where extra or different hoppers or inlets are used, do not use the table. Recalculate counterweight mass by using the formula.

6. Mount the rubbish chute section components as described in Chapter 8.5. Substitute the term 'centre bracket' with the term "chute support lugs" (see Step 3)

* Safety factor for load chains is 4 to 1 we recommend however at mounting points 6 to 1.

8.5 Installing the Rubbish Chutes – single Load Hopper.

Refer to Fig. 7

- Fit the top Rubbish Chute section into the Centre Bracket. Ensure the Chain Bracket lugs fit firmly into the Mounting Lugs on the Centre Bracket. Gravity will hold this Rubbish Chute section in place.
- Attach the second Rubbish Chute section by fitting the Chains from the top Rubbish Chute section over the Chain Bracket of the second Rubbish Chute section.
- Continue fitting additional Rubbish Chute sections until system length is achieved.
- Fit the Load Hopper into the top Rubbish Chute section securely.
- For ease of installation, a special hand winch is available to lift all Rubbish Chute sections. Fit the winch to the Centre Bracket, attach all Rubbish Chute sections together on the ground, attach the winch and lift up and fit the top Rubbish Chute section onto the Centre Bracket.

8.6 Installing multi-level Rubbish Chute systems.

- For ease of installation, fit a Centre Bracket at each loading level.
- Starting at the lowest level fit the Rubbish Chutes as described in Chapter 8.4. Fit a Load Hopper.
- Place the next string of Rubbish Chute sections into the next Centre Bracket and fit the last Rubbish Chute section of that string into the Load Hopper.
- Join the Rubbish Chute sections together through the Load Hopper by using extension chains.
- Continue up, until the required height is achieved.
- Alternatively, join Rubbish Chute sections and load hoppers up to 40m in length and lift into a Centre Bracket.

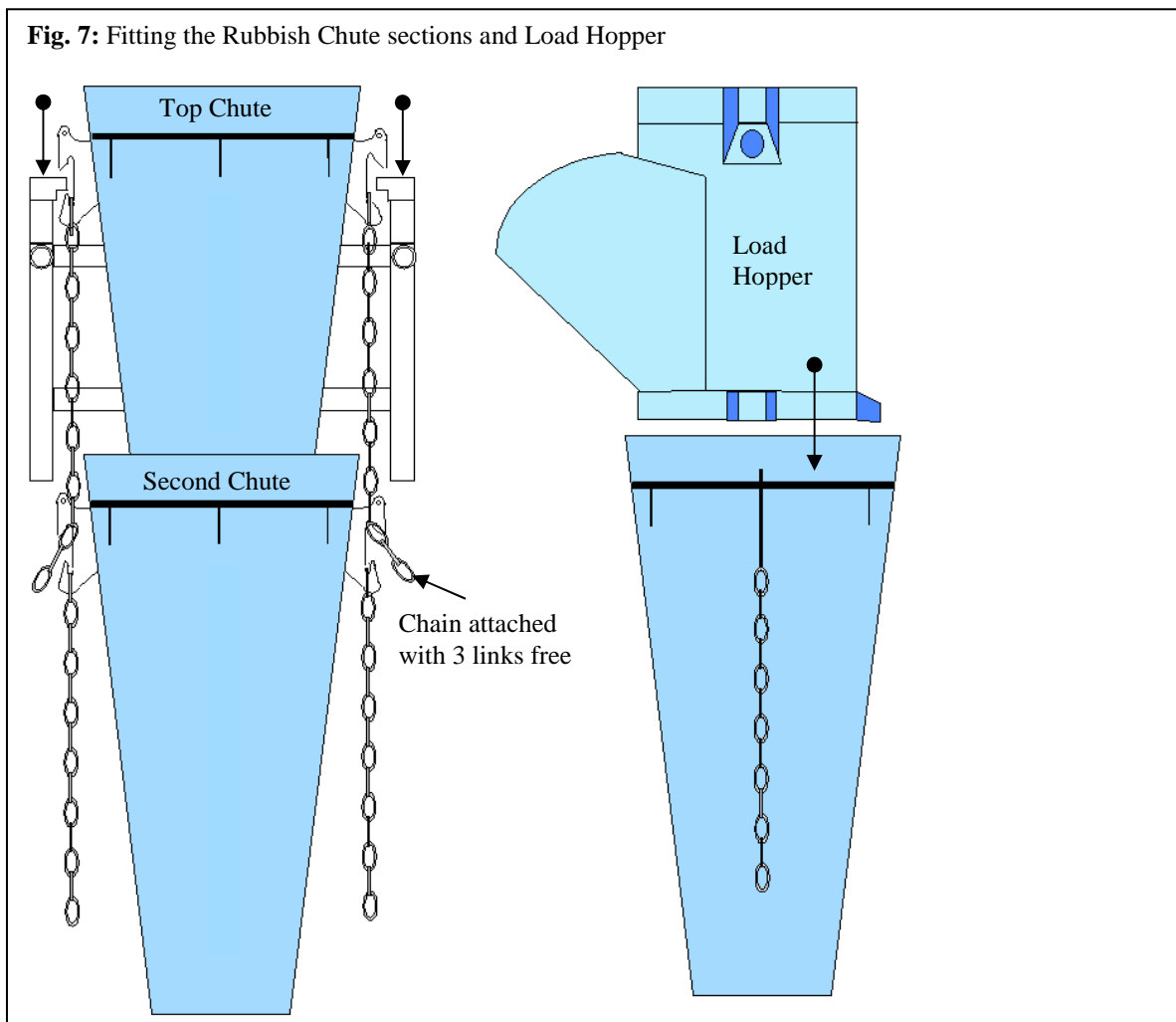

9. Removal

- Removal is the reverse of the instructions given for Installation